

Range Masters "Fun" Shoot

Results for June 15, 2010

Place	Name (Note)	Div.	Shoot Total	Total Points Down	Stage 1	String 1	PD	Stage 2	String 1	PD	Stage 3	String 1	String 2	PD
1	Kemp, Tony	O	75.94	25	27.08	20.08	14	21.18	15.68	11	27.68	12.92	14.76	0
2	Olson, Landon	NO	78.97	10	31.64	29.64	4	19.46	16.46	6	27.87	12.70	15.17	0
3	Mathis, David	NO	79.65	18	24.99	20.99	8	19.95	14.95	10	34.71	18.43	16.28	0
4	McGregor, Scott	NO	84.15	30	33.28	19.28	28	20.78	19.78	2	30.09	14.99	15.10	0
5	Wakamatsu, Josh (4)	NO	87.60	17	33.17	28.67	9	20.77	16.77	8	33.66	17.55	16.11	0
6	Wakamatsu, Josh (9)	NO	91.96	19	31.18	26.68	9	22.47	17.47	10	38.31	20.60	17.71	0
7	Gustaveson, Michael	O	93.08	28	36.81	28.31	17	24.25	18.75	11	32.02	15.19	16.83	0
8	Majers, Steve	O	103.18	45	28.10	26.10	4	33.22	15.72	35	41.86	18.92	19.94	6
9	Peterson, Andy	NO	115.25	51	38.60	28.60	20	30.07	19.57	21	46.58	19.70	21.88	10
10	Gonzalez, Francisco	NO	115.32	35	33.83	25.33	17	31.18	25.18	12	50.31	23.97	23.34	6
11	DeLeeuw, Dave	O	119.09	44	26.85	21.85	10	38.62	21.62	34	53.62	25.54	28.08	0
12	Ursulich, Ryan	NO	120.85	50	35.06	27.06	16	32.68	18.68	28	53.11	16.81	33.30	6
13	Kemp, Tony	NO	128.99	43	33.21	29.71	7	29.33	11.33	36	66.45	29.85	36.60	0
14	Spensko, Shane	NO	129.04	47	38.30	33.80	9	31.31	22.31	18	59.43	21.79	27.64	20
15	Phillips, RDan	NO	143.23	49	48.48	42.98	11	42.83	23.83	38	51.92	26.88	25.04	0
16	Waldo, Ralph	NO	147.06	59	45.02	37.02	16	43.38	21.88	43	58.66	33.69	24.97	0
17	Gustaveson, Michael	O	148.32	27	30.70	24.70	12	47.34	39.84	15	70.28	40.96	29.32	0
18	Sorenson, Sam	NO	151.43	67	37.06	28.06	18	31.86	17.36	29	82.51	30.01	42.50	20
19	Price, Mike	NO	160.82	42	37.36	31.86	11	39.66	24.16	31	83.80	38.94	44.86	0
20	Archer, Johathon (1)	NO	163.55	75	45.05	31.05	28	40.90	17.40	47	77.60	46.73	30.87	0
21	Mallon, Jim	NO	165.55	62	52.78	46.28	13	55.90	31.40	49	56.87	28.03	28.84	0
22	Redford, "Red" (Rev)	NO	169.53	48	52.94	45.94	14	41.16	24.16	34	75.43	42.94	32.49	0
23	Christriansen, Reed	NO	172.89	50	40.44	30.44	20	34.83	24.83	20	97.62	52.34	40.28	10
24	Reese, Howard	NO	188.56	86	57.10	43.60	27	49.28	19.78	59	82.18	41.97	40.21	0
25	Van Ausdal, Brian	NO	189.44	72	52.38	41.38	22	49.10	24.10	50	87.96	35.68	52.28	0
26	Holladay, Jason	NO	190.47	96	42.55	36.55	12	41.47	24.47	34	106.45	37.24	44.21	50
27	Reese, Howard	O	207.93	96	55.70	41.70	28	49.76	30.76	38	102.47	54.74	32.73	30
28	Little, James	NO	233.68	113	52.85	20.35	65	28.47	19.47	18	152.36	64.02	73.34	30
29	Connors, Chris	NO	265.02	103	66.13	49.63	33	41.97	34.97	14	156.92	50.16	78.76	56
30	Rees, Jerry	O	273.38	193	65.28	47.78	35	63.19	17.19	92	144.91	47.33	64.58	66
31	McCandless, Larry	NO	276.00	93	60.05	37.05	46	41.75	23.25	37	174.20	72.18	97.02	10
32	Francis, Bob	NO	302.19	149	73.26	63.76	19	52.52	22.52	60	176.41	64.43	76.98	70
33	Starr, Scott	NO	323.49	126	39.05	29.55	19	50.62	20.12	61	233.82	109.53	101.29	46
34	McCandless, Larry	NO	DNF	DNF	51.75	43.25	17	42.46	22.96	39	DNF			
35	Archer, Johathon (2)	NO	NS	194	42.75	33.25	19	45.57	18.07	55	NS	48.70	NS	120

Notes:

- PD = Points Down = .5 seconds x Points Down
- Div. = Division: O = Optic; NO = Non-Optic
- (Rev) = Revolver
- XX Indicates that the Points Down value includes some kind of penalty (Procedural Error, Hits on Non-Threat, Misses on Steel, etc.)
- DNF = Did Not Finish
- NS = No Score
- NT = No Time

Range Masters “Fun” Shoot

Stage 1 - “Topsy Turvey”

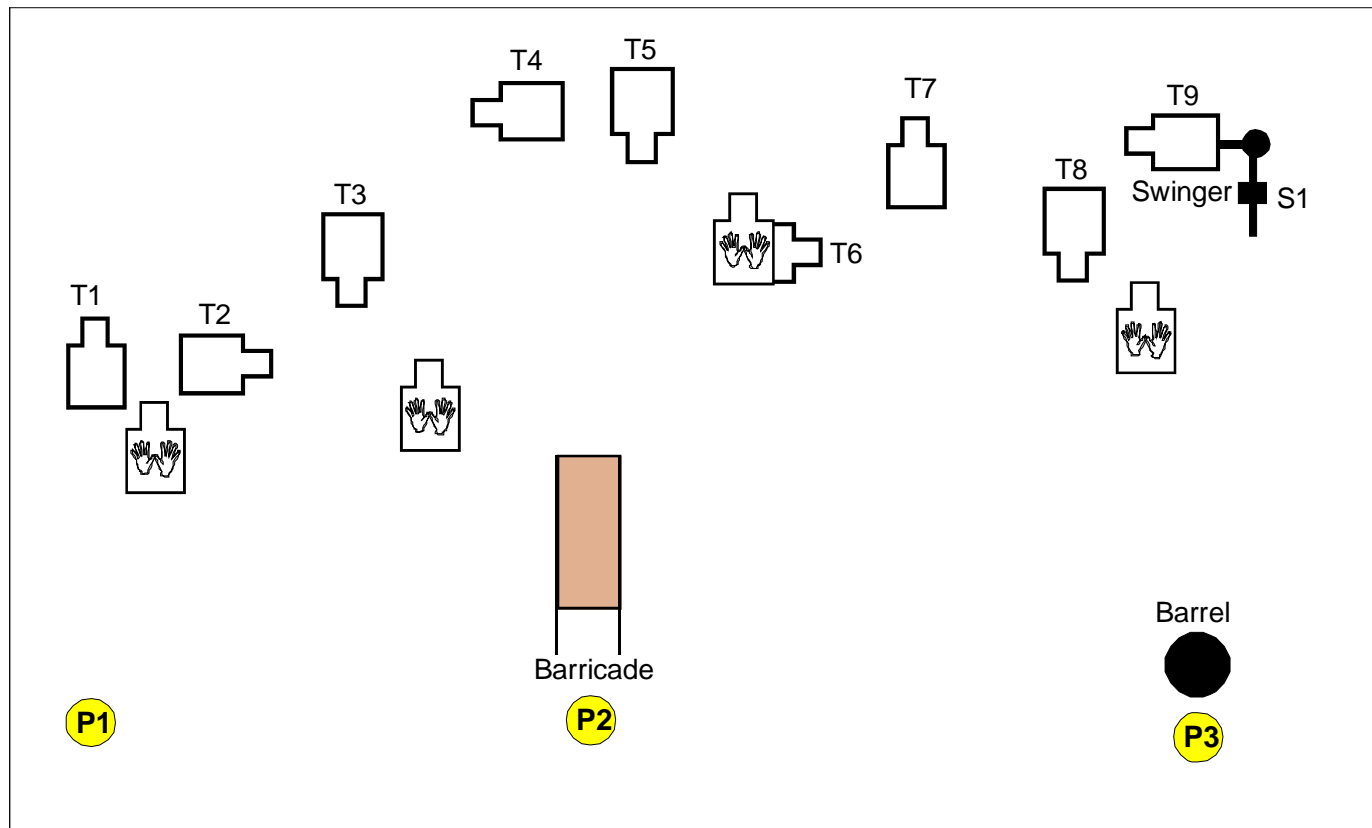

Round Count:
String 1 = **19 Minimum**
(**19** rounds for the stage)

Vickers Count
(Can make up shots)

String 1 -

- Shooter starts fully loaded at **P1**. All targets get **2 rounds** (Body or Head).
- At the sound of the buzzer, draw and engage **T1 - T3 while moving to P2**.
 - **After reaching P2**, while **properly using cover**, engage **T4 from the Left side** of the Barricade and **T5 from the Right side** of the Barricade.
 - Then, **while moving to P3**, engage **T6 and T7**.
 - **After reaching cover at P3**, engage **T8 from the Left side** of the Barrel, then from the **Right side** of the Barrel, knock down **S1** to trip the Swinger, then engage the Swinger (**T9**).
 - Reload as necessary using cover when appropriate.

Notes:

1. DO NOT SHOOT THE WALLS!
2. Use proper cover when engaging targets from cover.
3. Shooter must be moving while engaging targets between each position.
4. Shooter must perform at least 1 reload during the string.

Range Masters “Fun” Shoot

Stage 2 - “Get to the Prize”

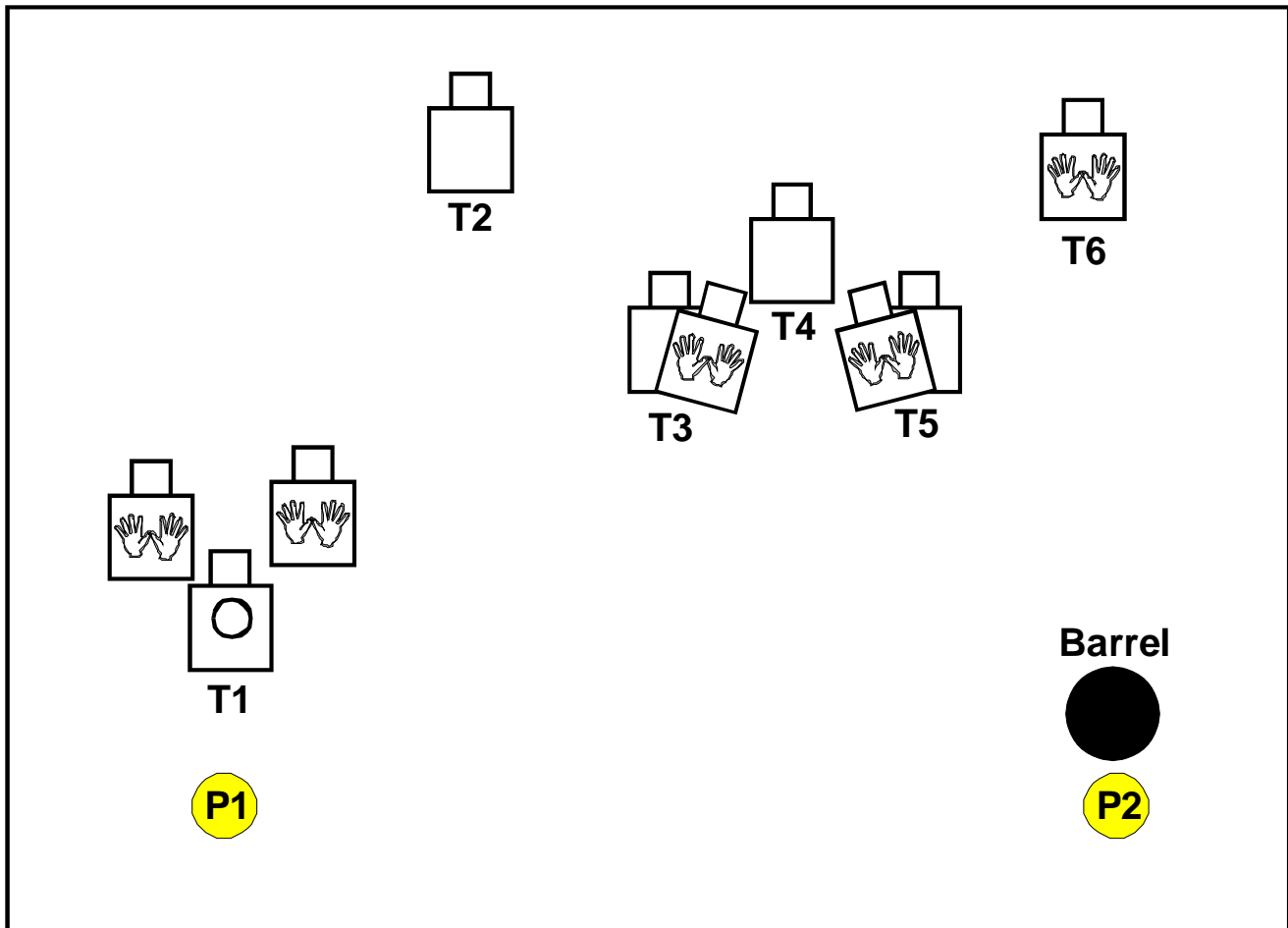

Round Count:

String 1 = **16** Maximum
(**16** rounds for the stage)

Limited Vickers Count

(Cannot make up shots)

String 1 -

Shooter starts at **P1** with **no more than 6 rounds** in the gun.

- At the sound of the buzzer, draw and engage **T1** with **2 rounds From Retention**.
- **While moving to P2**, engage **T2** thru **T5** with **3 rounds each** (Body or Head).
- **AFTER REACHING P2**, with the proper use of cover, engage **T6** with **2 rounds to the HEAD**.

Notes:

1. Shooter must be moving while engaging **T2** thru **T5**.
2. **DO NOT ENGAGE T6 UNTIL YOU REACH P2!**

Range Masters “Fun” Shoot

Stage 3 - “Aquire and Admire”

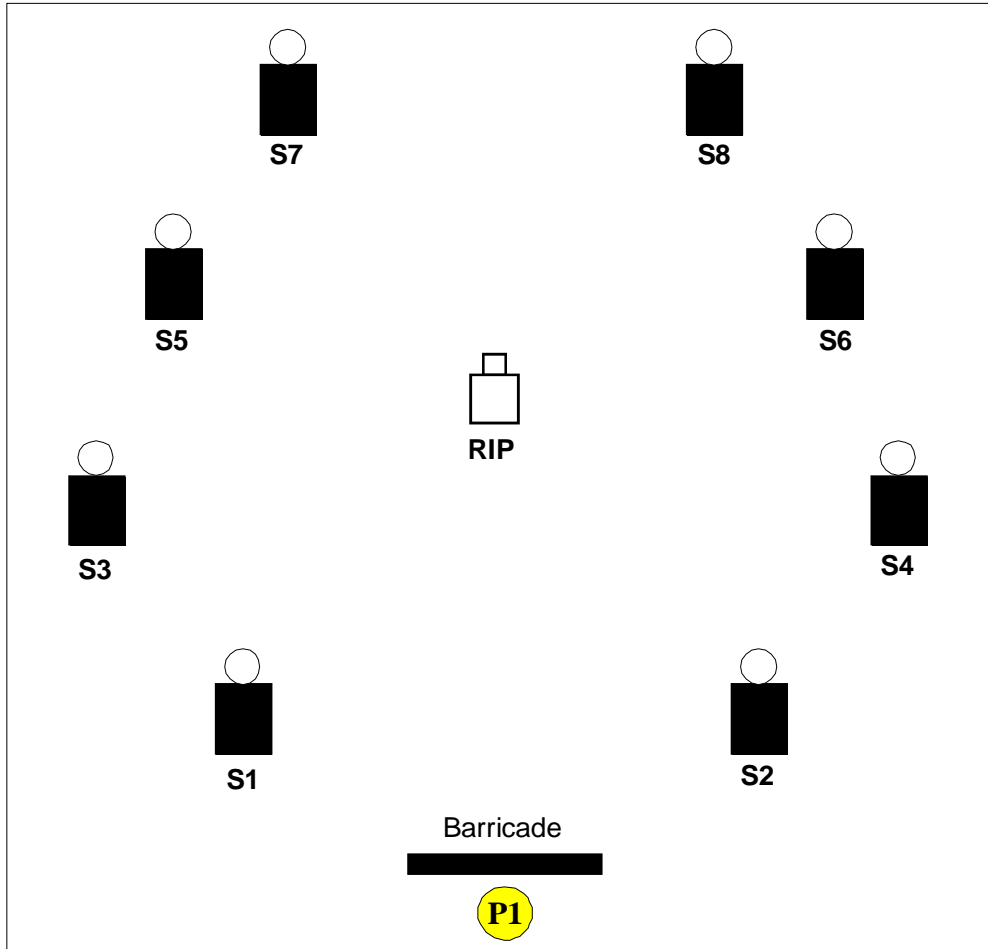

Round Count:
String 1 = 12 Minimum
String 2 = 12 Minimum
24 rounds MIN for stage.

Scoring:
Vickers Scoring

String 1 -

Shooter starts fully loaded behind Barricade at P1.

- At the sound of the buzzer, **draw and shoot the plates and RIP target in the following order: S1, RIP, S2; S4, RIP, S3; S5, RIP, S6; S8, RIP, S7**
- Change sides of barricade as necessary to aquire targets.
- Reload as necessary.

String 2 -

Shooter starts fully loaded behind Barricade at P1.

- At the sound of the buzzer, **draw and shoot the plates and RIP target in the following order: S8, RIP, S7; S5, RIP, S6; S4, RIP, S3; S1, RIP, S2**
- Change sides of barricade as necessary to aquire targets.
- Reload as necessary.

Notes -

1. All “S”plates left standing will be counted as a 5-second Miss-On-Steel Penalty.
2. If the RIP target is missed during the flow of shooting the 2 side steel plates, it must be hit before going on to the next row of targets to prevent a Procedural Penalty.